

ELFOSPACE BOX2

“Cassette” type water terminal unit for indoor installation

ELFOSPACE BOX2 005.1-041.0

- ▶ Suited for installation in standard suspended ceilings with 600 x 600 mm module.
- ▶ Very low sound levels for units of size 800 x 800 mm.
- ▶ Available in electro-mechanical or electronic version with set-up for connection to ELFOControl² or general supervisors.
- ▶ New version with infra-red remote control.
- ▶ The unit comes with a condensate drain pump (650 mm vertical).
- ▶ Available with DC Brushless ventilating unit (optional).



Nominal cooling capacity from 1,98 to 11,1kW
Nominal heating capacity from 2,37 to 13,2kW

Standard unit specifications

Structure

In galvanized sheet metal with internal thermal insulation (closed-cell expanded polyethylene thickness 10 mm) and an anti-condensation barrier on the external panel.

Internal exchanger

It is composed of copper pipes and aluminium fins fastened to tube with a process of mechanical expansion and suitably shaped. The batteries are with 1, 2 or 3 rows for 2 pipe models and 2+1 rows for 4 pipe models (the heating row is on the inside part of the battery). The heat exchanger is not suitable for use in corrosive atmosphere or in environments where aluminium may be subject to corrosion.

Fan

The fan-motor assembly, hung on anti-vibration devices, is especially quiet. The radial fan with single intake is designed to optimize improvement using wing-profile rotor blades with a special shape that reduces turbulence, increasing efficiency and reducing noise. The fans are coupled to a single-speed electric motor with characteristics of the windings designed to optimize performance and limit energy consumption. The motor is single phase, voltage 230V / 50 Hz, insulation B and integrated klixon. The variation in speed of the fan occurs by means of the use of an auto-transformer with six different output voltages. The units use 3 preset speeds with the possibility, during system adjustment, to modify them.

Filtration

Washable renewable synthetic filter, easily accessible.

Drain pan

In thermocoupled ABS with high-density expanded polystyrene, with preformed air passages suitable shaped to allow passage of air. Fire reaction class B2 in accordance with standards DIN 4102. To ensure optimal runoff of condensation, the unit is standard equipped with a centrifugal condensation drain pump with static pressure of 650 mm, controlled directly by the electronic card to which is connected a float system to control the condensation and alarm level.

Electrical panel

Composed of a box outside the unit which contains the electronic control card (TR) whose connection terminals are easily accessible.

Configuration options

- CC4 - 4-pipe system
- CVMB - MB electronics for infra-red remote control (if selected, are excluded options: TR and CTSP1)
- CTSP1 - CLIVET TALK TERMINAL SPACE electronics with RS485 Modbus serial port (if selected, are excluded options: TR and CVMB)
- CPVM - Control additional card of 0-10V fan (available only with options: CTSP1)
- VEC - High efficiency EC fan (available only with options: CVMB and CTSP1)
- RE - Electric heaters

Accessories separately supplied

- PLAX - Plastic frame for air supply and return (obligatory accessory)
- MAUXX - Primary air kit
- CAUX - Auxiliary air distribution duct
- CONRX - Fresh air connection
- 2V2X - ON/OFF 2 way valve kit for 2-pipe system
- 2V4X - ON/OFF 2 way valve kit for 4-pipe system
- 3V2X - Three-way valve kit for 2-pipe system type "on/off"
- 3V4X - Three-way valve kit for 4-pipe system type "on/off"
- CIVX - Fairing for in-view installation
- TIMBX - Infra-red remote control with receiver for MB electronics
- HIDE2X - Remote control with E/I + 3V + on/off for wall installation
- HIDE3X - Plurifunctional remote control for wall installation
- HIDE2X - HID-T2 electronic room control
- HIDE3X - HID-T3 electronic room control
- PTABX - Remote probe for room air temperature for electromechanical thermostats
- DCPX - Control device for more units with a single room control

Configuration Code

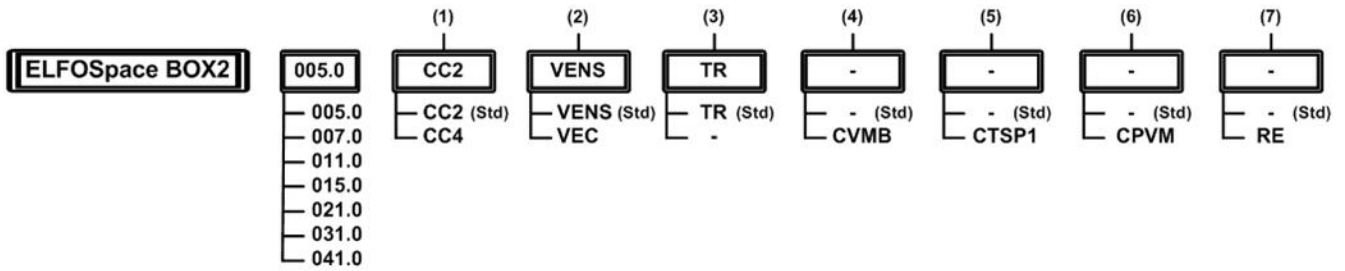

(1) Coil configuration

- CC2 - Coil configuration for 2 pipe system (standard)
- CC4 - Coil configuration for 4 pipe system

(2) Fans

- VENS - AC fans (standard)
- VEC - High efficiency EC fan (available only with options: CVMB and CTSP1)

(3) Electrical panel

- TR - Terminal boards for connection motor (standard)
- (-) - Not required

(4) Electronic version

- (-) - Not required (standard)
- CVMB - MB electronics for infra-red remote control (if selected, are excluded options: TR and CTSP1)

(5) Configuration options

- (-) - Not required (standard)
- CTSP1 - CLIVET TALK TERMINAL SPACE electronics with RS485 Modbus serial port (if selected, are excluded options: TR and CVMB)

(6) Additional cards

- (-) - Not required (standard)
- CPVM - Control additional card of 0-10V fan (available only with options: CTSP1)

(7) Electric heaters

- (-) - Not required (standard)
- RE - Electric heaters

General technical data - 2-pipe system (CC2)

Standard AC fan

Size			005.0	007.0	011.0	015.0	021.0	031.0	041.0
Cooling									
Cooling capacity	1	[kW]	1,98	2,68	4,33	5,02	6,16	9,51	11,1
Sensible capacity	1	[kW]	1,64	2,04	3,18	3,74	4,59	6,48	8,25
Total power input	1	[kW]	0,057	0,044	0,068	0,09	0,077	0,12	0,17
Heating									
Heating capacity	2	[kW]	2,37	3,10	5,12	5,86	7,26	11,1	13,2
Internal exchanger									
Number of rows		[Nr]	1	2	3	3	2	3	3
Water content		[l]	0,80	1,40	2,10	2,10	3,00	4,00	4,00
Water flow-rate	1	[l/s]	0,09	0,13	0,21	0,24	0,29	0,45	0,53
Water pressure drops	1	[kPa]	10,0	9,7	15,1	19,7	21,6	26,9	35,6
Water pressure drops	2	[kPa]	9,0	8,2	11,4	17,7	15,1	23,0	30,6
Air Handling Section Fans (Supply)									
Type of fans	3		RAD	RAD	RAD	RAD	RAD	RAD	RAD
Number of impellers		[Nr]	1	1	1	1	1	1	1
Air flow	4	[l/s]	169	144	197	244	317	417	506
Air flow	4	[m ³ /h]	610	520	710	880	1140	1500	1820
Connections									
Water fittings		["]	1/2"	1/2"	1/2"	1/2"	3/4"	3/4"	3/4"
Condensate drain	5	[mm]	14	14	14	14	14	14	14
Noise levels									
Sound pressure level (1 m)	6	[dB(A)]	36	32	40	46	34	39	44
Sound power level	6	[dB(A)]	49	45	53	59	48	53	58
Power supply STD									
Power supply STD		[V]	230/1/50	230/1/50	230/1/50	230/1/50	230/1/50	230/1/50	230/1/50

(1) Water temperature in / out 7°C / 12°C
Indoor air at 27°C D.B. / 19,5°C W.B.

Air flow at maximum speed (with air filter)

(2) Water inlet temperature = 50°C (water temperature differential = 10°C)

Indoor air temperature at 20°C D.B.

Air flow at maximum speed (with air filter)

(3) RAD = radial fan

(4) Air flow at maximum speed (with air filter)

(5) Intended as an external diameter

(6) Sound levels refer to units with full load under nominal test conditions. The sound pressure is measured at 1 m from the external surface of the unit in open field conditions.

Electrical data - 2-pipe system (CC2)

Standard AC fan

Voltage variation 230/1/50 ± 10%

Size			005.0	007.0	011.0	015.0	021.0	031.0	041.0
F.L.A. - Full load current at max admissible conditions									
FLA Total		[A]	0,27	0,20	0,32	0,45	0,36	0,53	0,74
F.L.I. - Full load power input at max admissible conditions									
FLI Total		[kW]	0,057	0,044	0,068	0,090	0,077	0,120	0,170

(1) Water temperature in / out 7°C / 12°C

Indoor air at 27°C D.B. / 19,5°C W.B.

Air flow at maximum speed (with air filter)

(2) Water inlet temperature = 50°C (water temperature differential = 10°C)

Indoor air temperature at 20°C D.B.

Air flow at maximum speed (with air filter)

General technical data - 4-pipe system (CC4)

Standard AC fan

Size			005.0	007.0	011.0	015.0	021.0	031.0	041.0
Cooling									
Cooling capacity	1	[kW]	2,33	2,7	3,93	4,53	6,34	8,77	10,2
Sensible capacity	1	[kW]	1,90	1,98	2,95	3,46	4,69	6,49	7,68
Total power input	1	[kW]	0,057	0,044	0,068	0,090	0,077	0,120	0,170
Heating									
Heating capacity	2	[kW]	3,03	3,46	3,35	3,79	9,10	8,56	9,80
Internal exchanger									
Number of rows		[Nr]	2+1	2+1	2+1	2+1	2+1	2+1	2+1
Water content		[l]	1 + 0,6	1,4 + 0,7	1,7 + 0,5	1,7 + 0,5	3,0 + 1,4	3,6 + 1,1	3,6 + 1,1
Water flow-rate	1	[l/s]	0,11 + 0,07	0,13 + 0,08	0,19 + 0,08	0,22 + 0,09	0,30 + 0,22	0,42 + 0,20	0,49 + 0,23
Water pressure drops	1	[kPa]	13,5	8,8	10,5	14,0	18,9	25,0	32,0
Water pressure drops	2	[kPa]	14,5	10,8	9,0	11,0	21,4	15,3	19,5
Air Handling Section Fans (Supply)									
Type of fans	3		RAD	RAD	RAD	RAD	RAD	RAD	RAD
Number of impellers		[Nr]	1	1	1	1	1	1	1
Air flow	4	[l/s]	169	144	197	244	317	417	506
Air flow	4	[m ³ /h]	610	520	710	880	1140	1500	1820
Connections									
Water fittings		["]	1/2"	1/2"	1/2"	1/2"	3/4"	3/4"	3/4"
Condensate drain	5	[mm]	14	14	14	14	14	14	14
Noise levels									
Sound pressure level (1 m)	6	[dB(A)]	36	32	40	46	34	39	44
Sound power level	6	[dB(A)]	49	45	53	59	48	53	58
Power supply STD									
Power supply STD		[V]	230/1/50	230/1/50	230/1/50	230/1/50	230/1/50	230/1/50	230/1/50

(1) Water temperature in / out 7°C / 12°C
Indoor air at 27°C D.B. / 19,5°C W.B.
Air flow at maximum speed (with air filter)
(2) Water inlet 70°C and outlet 60°C
Indoor air temperature at 20°C D.B.
Air flow at maximum speed (with air filter)

(3) RAD = radial fan
(4) Air flow at maximum speed (with air filter)
(5) Intended as an external diameter
(6) Sound levels refer to units with full load under nominal test conditions. The sound pressure is measured at 1 m from the external surface of the unit in open field conditions.

Electrical data - 4-pipe system (CC4)

Standard AC fan

Voltage variation 230/1/50 ± 10%

Size			005.0	007.0	011.0	015.0	021.0	031.0	041.0
F.L.A. - Full load current at max admissible conditions									
FLA Total		[A]	0,27	0,20	0,32	0,45	0,36	0,53	0,74
F.L.I. - Full load power input at max admissible conditions									
FLI Total		[kW]	0,057	0,044	0,068	0,090	0,077	0,120	0,170

(1) Water temperature in / out 7°C / 12°C
Indoor air at 27°C D.B. / 19,5°C W.B.
Air flow at maximum speed (with air filter)
(2) Water inlet 70°C and outlet 60°C
Indoor air temperature at 20°C D.B.
Air flow at maximum speed (with air filter)

Air throw

The air launch indicated in the tables must be considered only as a guideline, since it may vary substantially based on the size of the room where the unit is installed and the arrangement of furniture in the room.

The useful launch L refers to the distance between the unit and the point at which the air has a speed of 0.2 m/sec; if the louver is inclined at 30° (advisable during cooling phase), there is the so-called "Coanda" effect as shown in the first graph, whereas with an inclination of 45° (suggested in heating phase) there is a launch downwards as illustrated in the second graph.

With adjustable air diffusion louvers at 30°

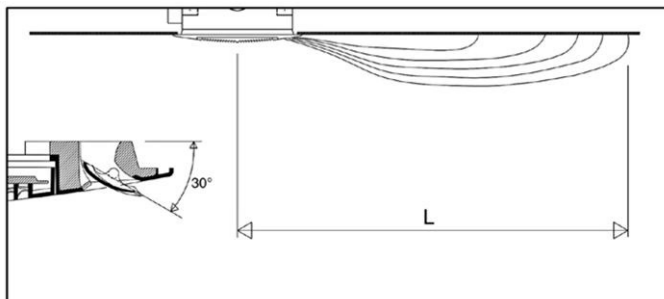

ELFOSpace BOX2	005.0 - 007.0			011.0			015.0		
Fan speed	Min	Med	Max	Min	Med	Max	Min	Med	Max
L (m)	3,0	3,5	3,8	3,0	3,8	4,5	3,5	4,2	5,0

ELFOSpace BOX2	021.0			031.0			041.0		
Fan speed	Min	Med	Max	Min	Med	Max	Min	Med	Max
L (m)	3,2	3,7	4,3	3,4	4,0	5,0	3,4	4,6	5,5

With adjustable air diffusion louvers at 45°

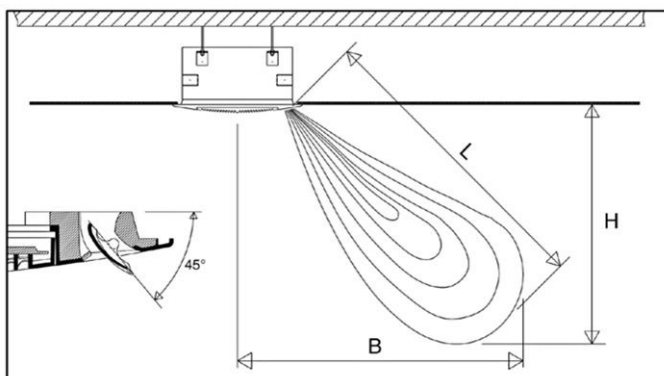

ELFOSpace BOX2	005.0 - 007.0			011.0			015.0		
Fan speed	Min	Med	Max	Min	Med	Max	Min	Med	Max
L (m)	3,3	3,9	4,2	3,3	4,2	4,8	3,9	4,5	5,2
H (m)	2,2	2,6	2,8	2,2	2,8	3,2	2,6	3,0	3,4
B (m)	2,5	2,9	3,1	2,5	3,1	3,6	2,9	3,4	3,9

ELFOSpace BOX2	021.0			031.0			041.0		
Fan speed	Min	Med	Max	Min	Med	Max	Min	Med	Max
L (m)	3,5	4,1	4,8	3,8	4,6	5,4	3,8	5,1	5,8
H (m)	2,2	2,6	3,0	2,4	2,8	3,4	2,4	3,1	3,6
B (m)	2,7	3,2	3,8	3,0	3,6	4,2	3,0	4,0	4,6



In winter sizing, use special care with buildings in which floor temperature is very low (for example lower than 5°C). In this situation, the air above the floor may be cooled to temperatures that are so low that they contrast the even diffusion of warm air coming out of the unit, thus reducing the launch value indicated in the table.

Primary air handling

The ELFOSpace BOX2 fan coil units can mix primary air with recirculation air. The maximum amount of external air is equal to 20% of the flow rate of the fan coil unit at medium speed. In any case from every corner it is possible to insert a maximum of 100 m³/h.

The units can draw primary air in 3 of the four corners (the fourth is reserved for condensation drainage). The inlet holes allow the use of standard rectangular ducts 110 x 55 mm or the adaptor for circular ducts (CONRX) shown below.

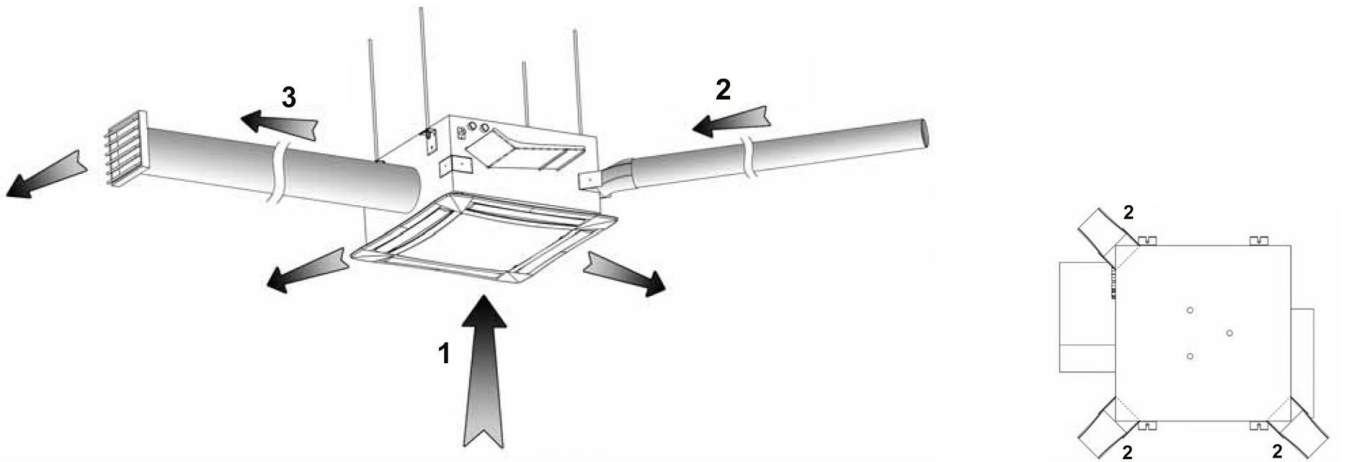

- 1. Indoor air intake
- 2. Primary air
- 3. Discharged air

Connection is very rapid and practical.

After removing the blank and the insulation inside the unit, the mounting plate is rolled back and the air duct with its V-shaped section must be pushed into the unit. The duct is then fixed to the mounting plate.

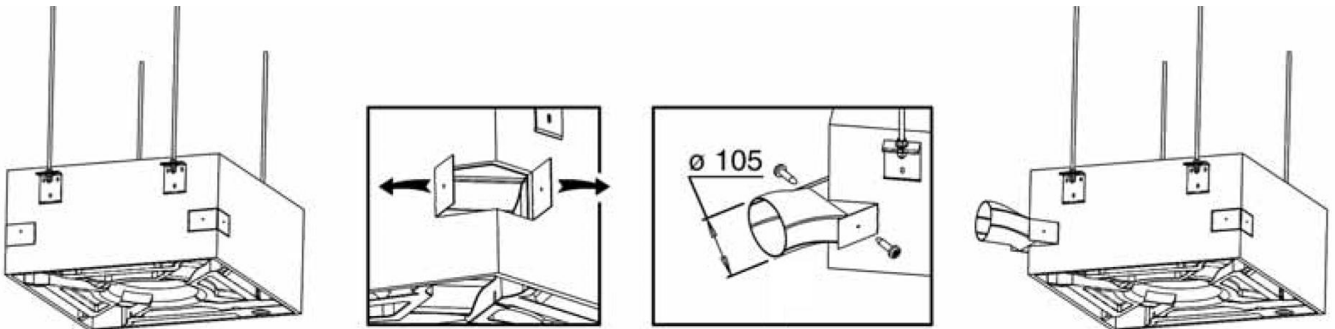

The fresh air must be filtered.

Operating limits

Size		005.0	007.0	011.0	015.0	021.0	031.0	041.0
Heating								
Max water inlet temperature	[°C]	80	80	80	80	80	80	80
Min water inlet temperature	[°C]	5	5	5	5	5	5	5
Max D.B. air inlet temperature	[°C]	40	40	40	40	40	40	40
Min D.B. air inlet temperature	[°C]	6	6	6	6	6	6	6
Cooling								
Max W.B. air inlet temperature	[°C]	40	40	40	40	40	40	40
Min W.B. air inlet temperature	[°C]	6	6	6	6	6	6	6
Max ambient relative humidity	[%]	75	75	75	75	75	75	75
Min ambient relative humidity	[%]	15	15	15	15	15	15	15
Maximum water side pressure	[bar]	8	8	8	8	8	8	8

Airflow / Fan speed

Size		005.0	007.0	011.0	015.0	021.0	031.0	041.0
Air flow (minimum speed)	[l/s]	86	86	89	119	175	197	197
Air flow (medium speed)	[l/s]	117	117	139	169	228	269	356
Air flow (max speed)	[l/s]	169	144	197	244	317	417	506

Corrective coefficients for yield based on air flow rate

CC2 - 2-pipe system

Fan speed	Size											
	005.0			007.0			011.0			015.0		
	Pf	Ps	Pt	Pf	Ps	Pt	Pf	Ps	Pt	Pf	Ps	Pt
Max	1,00	1,00	1,00	1,00	1,00	1,00	1,00	1,00	1,00	1,00	1,00	1,00
Med	0,82	0,80	0,80	0,86	0,85	0,85	0,77	0,75	0,76	0,76	0,75	0,69
Min	0,64	0,61	0,61	0,69	0,67	0,67	0,54	0,52	0,52	0,59	0,56	0,53
Fan speed	Size											
	021.0			031.0			041.0					
	Pf	Ps	Pt	Pf	Ps	Pt	Pf	Ps	Pt			
Max	1,00	1,00	1,00	1,00	1,00	1,00	1,00	1,00	1,00			
Med	0,79	0,78	0,78	0,72	0,70	0,70	0,77	0,75	0,75			
Min	0,65	0,63	0,63	0,56	0,54	0,53	0,48	0,46	0,46			

CC4 - 4-pipe system

Fan speed	Size											
	005.0			007.0			011.0			015.0		
	Pf	Ps	Pt	Pf	Ps	Pt	Pf	Ps	Pt	Pf	Ps	Pt
Max	1,00	1,00	1,00	1,00	1,00	1,00	1,00	1,00	1,00	1,00	1,00	1,00
Med	0,84	0,81	0,83	0,86	0,85	0,87	0,77	0,76	0,79	0,77	0,76	0,79
Min	0,64	0,60	0,64	0,69	0,67	0,70	0,55	0,53	0,59	0,60	0,58	0,63
Fan speed	Size											
	021.0			031.0			041.0					
	Pf	Ps	Pt	Pf	Ps	Pt	Pf	Ps	Pt			
Max	1,00	1,00	1,00	1,00	1,00	1,00	1,00	1,00	1,00			
Med	0,78	0,77	0,79	0,72	0,71	0,75	0,78	0,76	0,80			
Min	0,64	0,63	0,65	0,57	0,55	0,61	0,50	0,47	0,54			

Pf = Cooling capacity Ps = Sensible capacity Pt = Heating capacity

Water pressure drops

CC2 - 2-pipe system

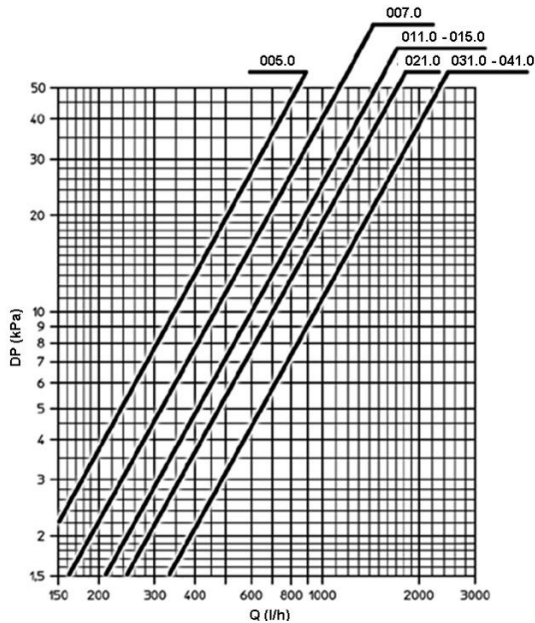

The pressure drops are referred to water medium temperature of 10° C.
For different temperatures multiply for the correction coefficient K.

Ta (°C)	20	30	40	50	60	70	80
K	0,94	0,90	0,86	0,82	0,78	0,74	0,70

Legend
 DP = Water pressure drop (kPa)
 Q = Water flow (l/h)
 Ta = Inlet water temperature (°C)

CC4 - 4-pipe system

Cooling operation

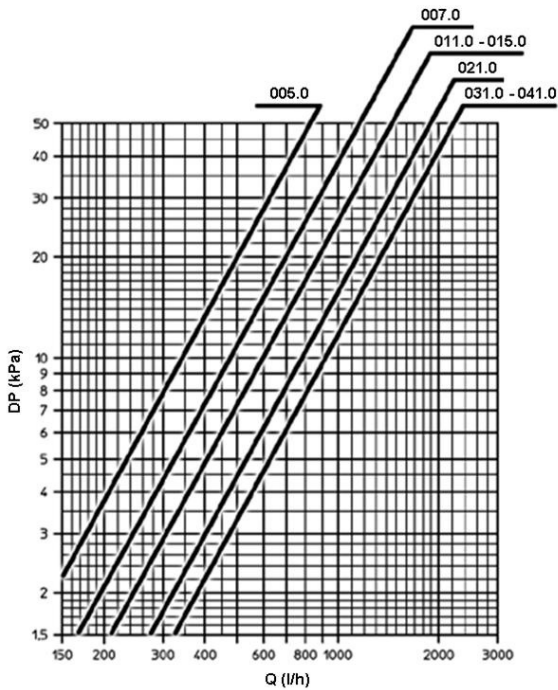

The pressure drops are referred to water medium temperature of 10°C.
For different temperatures multiply for the correction coefficient K.

Ta (°C)	20	30	40	50	60	70	80
K	0,94	0,90	0,86	0,82	0,78	0,74	0,70

Legend
 DP = Water pressure drop (kPa)
 Q = Water flow (l/h)
 Ta = Inlet water temperature (°C)

Heating operation

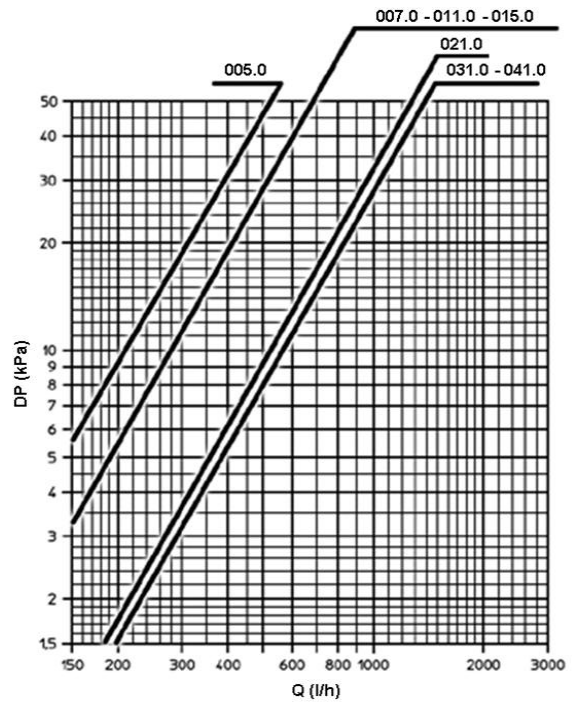

The pressure drops are referred to water medium temperature of 65°C.
For different temperatures multiply for the correction coefficient K.

Ta (°C)	40	50	60	70	80
K	1,14	1,08	1,02	0,96	0,90

Sound levels - Standard AC fan

Minimum speed

Size	Sound power level (dB)							Sound pressure level	Sound power level
	Octave band (Hz)								
	125	250	500	1000	2000	4000	8000	dB(A)	dB(A)
005.0	20	25	29	24	24	23	16	20	33
007.0	20	25	29	24	24	23	16	20	33
011.0	20	25	29	24	24	23	16	20	33
015.0	26	35	38	34	29	25	18	28	41
021.0	22	27	31	22	15	8	6	19	33
031.0	21	29	30	27	20	11	5	20	34
041.0	21	29	30	27	20	11	5	20	34

Medium speed

Size	Sound power level (dB)							Sound pressure level	Sound power level
	Octave band (Hz)								
	125	250	500	1000	2000	4000	8000	dB(A)	dB(A)
005.0	25	34	37	33	28	24	17	27	40
007.0	25	34	37	33	28	24	17	27	40
011.0	30	38	41	39	34	27	19	32	45
015.0	33	42	45	43	39	29	19	40	49
021.0	25	34	35	36	18	8	4	26	40
031.0	26	34	35	35	28	13	7	26	40
041.0	33	42	43	42	40	23	13	34	48

Maximum speed

Size	Sound power level (dB)							Sound pressure level	Sound power level
	Octave band (Hz)								
	125	250	500	1000	2000	4000	8000	dB(A)	dB(A)
005.0	33	42	45	43	39	29	19	36	49
007.0	30	38	41	39	34	27	19	32	45
011.0	34	45	50	46	42	33	24	40	53
015.0	41	51	54	54	52	43	30	46	59
021.0	32	40	43	45	29	16	8	34	48
031.0	31	40	50	47	44	42	26	39	53
041.0	41	52	53	52	50	41	31	44	58

Sound levels refer to units with full load under nominal test conditions. The sound pressure is measured at 1 m from the external surface of the unit in open field conditions.

2-pipe system (CC2)

Standard AC fan

Cooling performance

Size	Ta (°C) D.B. / W.B.	Inlet exchanger water temperature (°C)									
		5		7		10		13		15	
		Total power	Sensible power	Total power	Sensible power	Total power	Sensible power	Total power	Sensible power	Total power	Sensible power
		[kWf]	[kW _s]	[kWf]	[kW _s]	[kWf]	[kW _s]	[kWf]	[kW _s]	[kWf]	[kW _s]
005.0	22 / 16	1,63	1,40	1,29	1,29	0,87	0,87	0,55	0,55	0,32	0,32
	24 / 17	1,89	1,59	1,52	1,52	1,07	1,07	0,77	0,77	0,55	0,55
	26 / 18	2,15	1,76	1,76	1,72	1,27	1,27	0,98	0,98	0,77	0,77
	27 / 19	2,44	1,82	2,01	1,66	1,45	1,45	1,09	1,09	0,88	0,88
	28 / 20	2,74	1,91	2,29	1,73	1,66	1,65	1,16	1,16	0,98	0,98
	30 / 22	3,38	2,07	2,92	1,89	2,17	1,61	1,55	1,55	1,20	1,20
007.0	22 / 16	2,14	1,65	1,64	1,48	1,06	1,06	0,72	0,72	0,45	0,45
	24 / 17	2,47	1,87	1,94	1,70	1,29	1,29	0,98	0,98	0,72	0,72
	26 / 18	2,81	2,10	2,26	1,92	1,54	1,54	1,23	1,23	0,98	0,98
	27 / 19	3,17	2,21	2,63	1,99	1,81	1,75	1,20	1,20	1,11	1,11
	28 / 20	3,53	2,31	3,00	2,08	2,13	1,81	1,41	1,41	1,23	1,23
	30 / 22	4,30	2,51	3,76	2,29	2,89	1,95	1,98	1,71	1,48	1,48
011.0	22 / 16	3,49	2,59	2,67	2,27	1,68	1,68	1,19	1,19	0,76	0,76
	24 / 17	4,01	2,95	3,15	2,61	2,05	2,05	1,58	1,58	1,18	1,18
	26 / 18	4,55	3,31	3,65	2,96	2,46	2,46	1,97	1,97	1,58	1,58
	27 / 19	5,10	3,47	4,25	3,11	2,92	2,65	1,88	1,88	1,77	1,77
	28 / 20	5,67	3,63	4,85	3,28	3,46	2,78	2,25	2,25	1,96	1,96
	30 / 22	6,86	3,95	6,04	3,60	4,71	3,07	3,22	2,61	2,36	2,36
015.0	22 / 16	4,02	3,04	3,08	2,68	1,95	1,95	1,38	1,38	0,87	0,87
	24 / 17	4,62	3,46	3,63	3,09	2,39	2,39	1,85	1,85	1,38	1,38
	26 / 18	5,25	3,87	4,21	3,50	2,86	2,86	2,30	2,30	1,85	1,85
	27 / 19	5,89	4,06	4,93	3,66	3,38	3,15	2,19	2,19	2,08	2,08
	28 / 20	6,56	4,25	5,59	3,84	3,98	3,29	2,61	2,61	2,30	2,30
	30 / 22	7,95	4,62	6,98	4,21	5,42	3,60	3,71	3,09	2,75	2,75
021.0	22 / 16	4,95	3,71	3,80	3,32	2,43	2,43	1,68	1,68	1,07	1,07
	24 / 17	5,69	4,22	4,48	3,81	2,96	2,96	2,26	2,26	1,68	1,68
	26 / 18	6,44	4,74	5,20	4,30	3,55	3,55	2,81	2,81	2,25	2,25
	27 / 19	7,23	4,97	6,05	4,49	4,17	3,91	2,74	2,74	2,53	2,53
	28 / 20	8,04	5,20	6,85	4,70	4,92	4,05	3,24	3,24	2,80	2,80
	30 / 22	9,74	5,65	8,56	5,15	6,64	4,40	4,58	3,82	3,41	3,41
031.0	22 / 16	7,70	5,69	5,89	4,95	3,68	3,68	2,64	2,64	1,69	1,69
	24 / 17	8,82	6,47	6,94	5,70	4,51	4,51	3,51	3,51	2,63	2,63
	26 / 18	10,00	7,25	8,05	6,46	5,41	5,41	4,34	4,34	3,50	3,50
	27 / 19	11,26	7,62	9,33	6,80	6,43	5,75	4,12	4,12	3,92	3,92
	28 / 20	12,50	7,98	10,69	7,19	7,62	6,05	4,94	4,94	4,33	4,33
	30 / 22	15,09	8,67	13,30	7,90	10,41	6,74	7,12	5,67	5,22	5,09
041.0	22 / 16	8,94	6,73	6,85	5,91	4,33	4,33	3,09	3,09	1,97	1,97
	24 / 17	10,25	7,66	8,06	6,80	5,29	5,29	4,13	4,13	3,09	3,09
	26 / 18	11,63	8,58	9,35	7,70	6,33	6,33	5,14	5,14	4,13	4,13
	27 / 19	13,12	9,08	10,89	8,07	7,49	6,90	4,85	4,85	4,63	4,63
	28 / 20	14,59	9,42	12,45	8,51	8,86	7,24	5,79	5,79	5,12	5,12
	30 / 22	17,66	10,23	15,54	9,33	12,06	7,97	8,25	6,79	6,10	6,10

Technical data referred to the following conditions:

Air flow at maximum speed (with air filter)

Water temperature differential = 5°C

Ta = Air intake temperature

D.B. = Dry bulb

W.B. = Wet bulb

kWf = Cooling capacity in kW

kW_s = sensible cooling capacity (kW)

Heating performance

Size	Ta (°C)	Inlet exchanger water temperature (°C)							
		35	40	45	50	55	60	70	80
		Total power	Total power	Total power	Total power	Total power	Total power	Total power	Total power
		[kWt]	[kWt]	[kWt]	[kWt]	[kWt]	[kWt]	[kWt]	[kWt]
005.0	10	1,91	2,48	3,05	3,61	4,17	4,73	5,85	6,96
	15	1,35	1,91	2,47	3,02	3,58	4,13	5,23	6,33
	18	1,00	1,57	2,13	2,68	3,23	3,78	4,87	5,97
	20	0,77	1,35	1,90	2,45	3,00	3,55	4,64	5,72
	22	0,53	1,12	1,68	2,23	2,77	3,32	4,40	5,48
	24	0,26	0,90	1,46	2,01	2,55	3,09	4,17	5,25
007.0	10	2,50	3,17	3,84	4,50	5,16	5,83	7,14	8,45
	15	1,80	2,48	3,14	3,80	4,45	5,11	6,41	7,70
	18	1,38	2,07	2,73	3,39	4,04	4,69	5,97	7,26
	20	1,09	1,79	2,46	3,11	3,76	4,41	5,69	6,97
	22	0,79	1,52	2,19	2,84	3,49	4,13	5,41	6,68
	24	0,43	1,24	1,92	2,58	3,22	3,86	5,13	6,40
011.0	10	3,98	5,01	6,02	7,03	8,04	9,04	11,03	13,02
	15	2,91	3,94	4,95	5,96	6,95	7,94	9,91	11,86
	18	2,26	3,31	4,32	5,32	6,31	7,29	9,24	11,19
	20	1,81	2,89	3,91	4,90	5,89	6,86	8,81	10,74
	22	1,34	2,46	3,49	4,49	5,47	6,44	8,38	10,30
	24	0,76	2,03	3,08	4,08	5,06	6,03	7,95	9,84
015.0	10	4,66	5,88	7,09	8,30	9,49	10,68	13,06	15,43
	15	3,39	4,62	5,83	7,02	8,20	9,37	11,72	14,06
	18	2,62	3,87	5,08	6,27	7,44	8,61	10,94	13,26
	20	2,10	3,38	4,58	5,77	6,94	8,11	10,44	12,73
	22	1,54	2,87	4,09	5,28	6,45	7,61	9,91	12,20
	24	0,87	2,36	3,60	4,79	5,96	7,11	9,41	11,69
021.0	10	5,91	7,44	8,97	10,48	11,99	13,49	16,49	19,47
	15	4,31	5,85	7,38	8,87	10,36	11,85	14,81	17,75
	18	3,34	4,91	6,43	7,92	9,41	10,88	13,82	16,73
	20	2,68	4,28	5,81	7,30	8,78	10,25	13,17	16,07
	22	1,97	3,65	5,19	6,68	8,15	9,61	12,52	15,41
	24	1,13	3,00	4,57	6,06	7,54	8,99	11,89	14,76
031.0	10	9,07	11,36	13,62	15,87	18,11	20,33	24,76	29,18
	15	6,66	8,98	11,24	13,46	15,67	17,87	22,24	26,59
	18	5,20	7,56	9,83	12,04	14,25	16,43	20,76	25,08
	20	4,20	6,62	8,89	11,11	13,30	15,47	19,79	24,08
	22	3,12	5,66	7,96	10,18	12,37	14,53	18,83	23,10
	24	1,81	4,69	7,03	9,27	11,45	13,60	17,87	22,12
041.0	10	10,74	13,52	16,25	18,96	21,65	24,34	29,70	35,03
	15	7,87	10,66	13,37	16,07	18,73	21,38	26,66	31,93
	18	6,12	8,95	11,68	14,36	17,01	19,65	24,89	30,11
	20	4,91	7,82	10,56	13,24	15,88	18,50	23,72	28,90
	22	3,62	6,67	9,44	12,12	14,76	17,37	22,57	27,72
	24	2,07	5,50	8,32	11,02	13,65	16,26	21,42	26,55

Technical data referred to the following conditions:

Air flow at maximum speed (with air filter)

Different between inlet/outlet water temperature = 10°C

Ta = Air intake temperature

kWt = Heating capacity in kW

4-pipe system (CC4)

Standard AC fan

Cooling performance

Size	Ta (°C) D.B. / W.B.	Inlet exchanger water temperature (°C)									
		5		7		10		13		15	
		Total power	Sensible power	Total power	Sensible power	Total power	Sensible power	Total power	Sensible power	Total power	Sensible power
		[kWf]	[kW _s]	[kWf]	[kW _s]	[kWf]	[kW _s]	[kWf]	[kW _s]	[kWf]	[kW _s]
005.0	22 / 16	1,88	1,60	1,48	1,48	1,02	1,02	0,66	0,66	0,40	0,40
	24 / 17	2,16	1,82	1,73	1,71	1,20	1,20	0,91	0,91	0,66	0,66
	26 / 18	2,46	2,03	2,00	1,92	1,43	1,43	1,15	1,15	0,91	0,91
	27 / 19	2,87	2,08	2,35	1,90	1,64	1,64	1,27	1,27	1,03	1,03
	28 / 20	3,12	2,17	2,61	1,97	1,89	1,83	1,31	1,31	1,15	1,15
	30 / 22	3,82	2,34	3,31	2,14	2,50	1,87	1,76	1,75	1,36	1,36
007.0	22 / 16	2,17	1,64	1,67	1,47	1,07	1,07	0,73	0,73	0,46	0,46
	24 / 17	2,50	1,87	1,97	1,69	1,31	1,31	0,98	0,98	0,73	0,73
	26 / 18	2,84	2,10	2,29	1,91	1,56	1,56	1,23	1,23	0,98	0,98
	27 / 19	3,19	2,20	2,65	1,98	1,84	1,74	1,21	1,21	1,11	1,11
	28 / 20	3,55	2,31	3,02	2,08	2,16	1,80	1,43	1,43	1,23	1,23
	30 / 22	4,32	2,51	3,79	2,29	2,92	1,95	2,01	1,70	1,50	1,50
011.0	22 / 16	3,19	2,44	2,44	2,16	1,56	1,56	1,09	1,09	0,68	0,68
	24 / 17	3,66	2,78	2,88	2,16	1,90	1,90	1,47	1,47	1,09	1,09
	26 / 18	4,17	3,11	3,34	2,81	2,27	2,27	1,84	1,84	1,47	1,47
	27 / 19	4,71	3,26	3,95	2,95	2,68	2,54	1,80	1,80	1,65	1,65
	28 / 20	5,24	3,41	4,46	3,08	3,16	2,65	2,08	2,08	1,83	1,83
	30 / 22	6,37	3,71	5,58	3,38	4,31	2,89	2,94	2,49	2,19	2,19
015.0	22 / 16	3,64	2,85	2,81	2,55	1,81	1,81	1,26	1,26	0,78	0,78
	24 / 17	4,19	3,25	3,30	2,93	2,20	2,20	1,71	1,71	1,26	1,26
	26 / 18	4,77	3,63	3,83	3,31	2,63	2,63	2,14	2,14	1,71	1,71
	27 / 19	5,40	3,80	4,55	3,46	3,09	3,02	2,20	2,20	1,92	1,92
	28 / 20	6,02	3,98	5,10	3,59	3,62	3,13	2,41	2,41	2,14	2,14
	30 / 22	7,32	4,31	6,41	3,93	4,91	3,37	3,37	2,95	2,53	2,53
021.0	22 / 16	5,13	3,82	3,92	3,39	2,50	2,50	1,72	1,72	1,08	1,08
	24 / 17	5,89	4,34	4,63	3,89	3,05	3,05	2,31	2,31	1,72	1,72
	26 / 18	6,67	4,87	5,38	4,40	3,65	3,65	2,87	2,87	2,30	2,30
	27 / 19	7,48	5,11	6,22	4,59	4,31	3,98	2,80	2,80	2,59	2,59
	28 / 20	8,31	5,35	7,09	4,83	5,08	4,14	3,33	3,33	2,87	2,87
	30 / 22	10,07	5,82	8,86	5,31	6,88	4,53	4,73	3,89	3,51	3,51
031.0	22 / 16	7,36	5,46	5,65	4,79	3,56	3,56	2,50	2,50	1,61	1,61
	24 / 17	8,44	6,21	6,65	5,51	4,35	4,35	3,33	3,33	2,50	2,50
	26 / 18	9,58	6,95	7,69	6,23	5,21	5,21	4,13	4,13	3,33	3,33
	27 / 19	10,71	7,29	8,81	6,49	6,17	5,58	3,99	3,99	3,73	3,73
	28 / 20	11,90	7,66	10,19	6,89	7,29	5,85	4,76	4,76	4,12	4,12
	30 / 22	14,38	8,29	12,68	7,56	9,89	6,45	6,80	5,49	5,03	4,97
041.0	22 / 16	8,50	6,43	6,54	5,69	4,18	4,18	2,92	2,92	1,86	1,86
	24 / 17	9,75	7,31	7,69	6,55	5,09	5,09	3,91	3,91	2,93	2,93
	26 / 18	11,07	8,18	8,91	7,40	6,08	6,08	4,86	4,86	3,91	3,91
	27 / 19	12,43	8,57	10,25	7,67	7,16	6,68	4,68	4,68	4,39	4,39
	28 / 20	13,81	8,96	11,79	8,10	8,43	6,96	5,56	5,56	4,85	4,85
	30 / 22	16,73	9,73	14,70	8,88	11,42	7,59	7,86	6,55	5,86	5,86

Technical data referred to the following conditions:

Air flow at maximum speed (with air filter)

Water temperature differential = 5°C

Ta = Air intake temperature

D.B. = Dry bulb

W.B. = Wet bulb

kWf = Cooling capacity in kW

kWs = Sensible cooling capacity (kW)

Heating performance

Size	Ta (°C)	Inlet exchanger water temperature (°C)							
		35	40	45	50	55	60	70	80
		Total power	Total power	Total power	Total power	Total power	Total power	Total power	Total power
		[kWt]	[kWt]	[kWt]	[kWt]	[kWt]	[kWt]	[kWt]	[kWt]
005.0	10	1,23	1,61	1,98	2,36	2,74	3,12	3,87	4,62
	15	0,85	1,23	1,60	1,98	2,35	2,73	3,47	4,22
	18	0,63	1,00	1,38	1,75	2,12	2,49	3,23	3,97
	20	0,48	0,86	1,23	1,60	1,97	2,34	3,04	3,82
	22	0,32	0,71	1,08	1,45	1,82	2,19	2,92	3,65
007.0	10	1,38	1,80	2,21	2,62	3,04	3,45	4,26	5,08
	15	0,97	1,38	1,79	2,20	2,60	3,01	3,82	4,63
	18	0,72	1,13	1,54	1,95	2,35	2,75	3,55	4,36
	20	0,55	0,97	1,38	1,78	2,18	2,58	3,36	4,18
	22	0,38	0,81	1,21	1,62	2,02	2,42	3,21	4,01
011.0	10	1,18	1,61	2,05	2,49	2,93	3,36	4,24	5,12
	15	0,77	1,19	1,62	2,06	2,49	2,92	3,78	4,66
	18	0,53	0,95	1,37	1,80	2,23	2,66	3,52	4,37
	20	0,37	0,78	1,21	1,63	2,06	2,48	3,35	4,20
	22	0,21	0,62	1,04	1,46	1,88	2,31	3,16	4,02
015.0	10	1,31	1,79	2,29	2,78	3,27	3,76	4,75	5,75
	15	0,85	1,33	1,81	2,29	2,78	3,26	4,24	5,22
	18	0,58	1,05	1,52	2,01	2,49	2,97	3,94	4,91
	20	0,40	0,87	1,34	1,82	2,30	2,78	3,79	4,70
	22	0,23	0,69	1,15	1,63	2,10	2,58	3,54	4,50
021.0	10	3,86	4,96	6,05	7,14	8,22	9,31	11,46	13,62
	15	2,74	3,84	4,93	6,01	7,07	8,14	10,28	12,41
	18	2,07	3,18	4,26	5,34	6,40	7,46	9,57	11,69
	20	1,62	2,74	3,82	4,89	5,95	7,01	9,11	11,23
	22	1,14	2,30	3,39	4,46	5,51	6,57	8,67	10,76
031.0	10	3,35	4,43	5,50	6,57	7,65	8,70	10,85	12,98
	15	2,30	3,36	4,42	5,48	6,54	7,60	9,71	11,82
	18	1,67	2,73	3,79	4,84	5,89	6,94	9,04	11,13
	20	1,24	2,31	3,37	4,42	5,46	6,51	8,57	10,68
	22	0,81	1,90	2,95	4,00	5,04	6,08	8,16	10,23
041.0	10	3,78	4,99	6,22	7,44	8,66	9,88	12,30	14,74
	15	2,58	3,79	5,00	6,20	7,40	8,61	11,02	13,43
	18	1,86	3,07	4,28	5,47	6,67	7,87	10,25	12,64
	20	1,39	2,60	3,79	4,99	6,18	7,38	9,81	12,13
	22	0,90	2,12	3,32	4,52	5,70	6,89	9,26	11,62
041.0	24	0,37	1,65	2,85	4,04	5,22	6,40	8,76	11,13

Technical data referred to the following conditions:
 Air flow at maximum speed (with air filter)
 Difference between inlet / outlet water temperature = 10°C
 Ta = Air intake temperature
 kWt = Heating capacity in kW

Configuration options

CVMB - MB electronics for infra-red remote control (if selected, are excluded options: TR and CTSP1)

For all size in 2 or 4-pipe version is available MB electronics for infra-red remote control. The system consists in a MB board and an infra-red remote control (TIMBX) supplied separately.

CTSP1 - CLIVET TALK TERMINAL SPACE electronics with RS485 Modbus serial port (if selected, are excluded options: TR and CVMB)

This is a card for control of the unit which, in addition to basic functions, allows it to be connected to a network of similar units managed centrally by ELFOControl or B.M.S.

This type of electronic card is suited for communicating via RS485 if connected to SP1 devices.

The microprocessor control installed in the unit receives operating settings from one of the following thermostats:

- HID-T2 - electronic room control for wall installation
- HID-TI2 - flush-mounted electronic room control
- HID-T3 - electronic room control for wall installation with humidity probe

Its functionalities are:

- control of minimum temperature of system water temperature
- control of manual or automatic speed fan
- control of on/off water valve
- digital input for remote on/off function or winter/summer
- fan control
- on/off control of electrical heating element or cumulative alarm relay.

The serial port with MODBUS protocol. Allows the cable connection between the units and the ELFOControl or B.M.S.

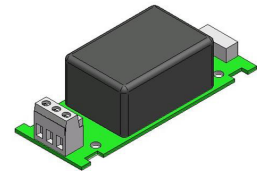
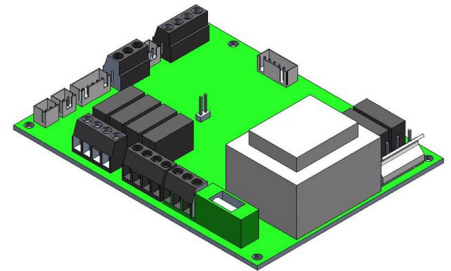

CPVM - Control additional card of 0-10V fan (available only with options: CTSP1)

Control additional card of 0-10V fans.

VEC - High efficiency EC fan (available only with options: CVMB and CTSP1)

The ELFOspace BOX2 series can be configured with an innovative brushless synchronous permanent magnet electric motor controlled by an inverter card that is directly installed on the unit.

The air flow can be varied continuously with a 0-10V signal.

The extreme efficiency, also at a low speed, makes possible a great reduction in electric consumption (more than 75% less in comparison to a traditional motor) with absorption values, under normal operating conditions, that are no greater than 10 Watt in the entire range.

The main advantages are:

- Large reduction in energy consumption, thanks to an optimal response to the thermal load of the environment during every moment of the day
- Operating silence at all rotation speeds
- Ability to operate at any rotation speed



Configuration not available for sizes 005.0 and 041.0.

Motor Absorption

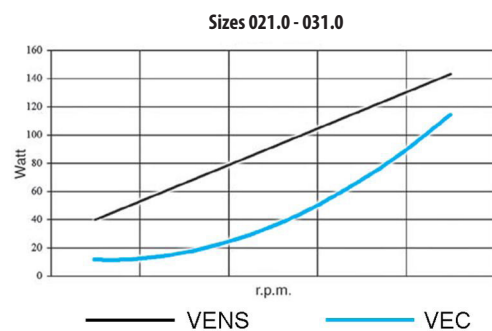
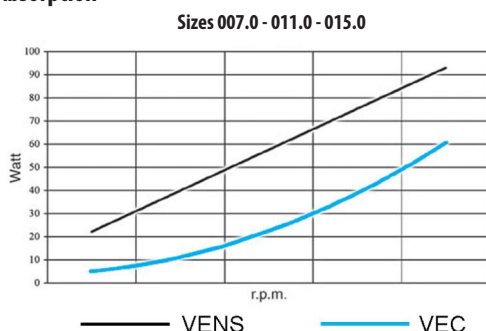

General technical data - 2-pipe system (CC2)

High efficiency EC fan

Size			007.0	011.0	015.0	021.0	031.0
Cooling							
Cooling capacity	1	[kW]	2,75	4,33	5,02	6,33	10,75
Sensible capacity	1	[kW]	2,09	3,18	3,74	4,72	7,94
Heating							
Heating capacity	2	[kW]	3,17	4,89	5,75	7,47	11,81
Internal exchanger							
Water flow-rate	1	[l/s]	0,13	0,21	0,24	0,3	0,51
Water pressure drops	1	[kPa]	10,1	15,1	19,7	22,7	33,6
Water pressure drops	2	[kPa]	8,70	13,10	17,70	19,50	28,80
Air Handling Section Fans (Supply)							
Air flow	3	[l/s]	149	197	244	324	492
Air flow	3	[m ³ /h]	535	710	880	1165	1170
Noise levels							
Sound press. level (1m)	4	[dB(A)]	34	41	47	34	43
Sound Power Level	4	[dB(A)]	47	54	60	48	57

(1) Water temperature in / out 7°C / 12°C

Indoor air at 27°C D.B. / 19,5°C W.B.

Air flow at maximum speed (with air filter)

(2) Water inlet temperature = 50°C (water temperature differential = 10°C)

Indoor air temperature at 20°C D.B.

Air flow at maximum speed (with air filter)

(3) Nominal airflow at maximum speed (with air filter)

(4) Sound levels refer to units with full load under nominal test conditions. The sound pressure is measured at 1 m from the external surface of the unit in open field conditions.

Electrical data - 2-pipe system (CC2)

High efficiency EC fan

Voltage variation 230/1/50 ± 10%

Size			007.0	011.0	015.0	021.0	031.0
F.L.A. - Full load current at max admissible conditions							
FLA Total		[A]	0,24	0,34	0,64	0,34	0,99
F.L.I. - Full load power input at max admissible conditions							
FLI Total		[kW]	0,016	0,031	0,062	0,033	0,108

(1) Water temperature in / out 7°C / 12°C

Indoor air at 27°C D.B. / 19,5°C W.B.

Air flow at maximum speed (with air filter)

(2) Water inlet temperature = 50°C (water temperature differential = 10°C)

Indoor air temperature at 20°C D.B.

Air flow at maximum speed (with air filter)

General technical data - 4-pipe system (CC4)

High efficiency EC fan

Size			007.0	011.0	015.0	021.0	031.0
Cooling							
Cooling capacity	1	[kW]	2,77	3,93	4,53	6,51	9,87
Sensible capacity	1	[kW]	2,08	2,95	3,46	4,83	7,4
Heating							
Heating capacity	2	[kW]	3,62	3,35	3,79	9,36	9,51
Internal exchanger							
Water flow-rate	1	[l/s]	0,13	0,21	0,24	0,3	0,51
Water pressure drops	1	[kPa]	9,5	10,5	13,1	19,8	30,1
Water pressure drops	2	[kPa]	11,7	9,0	11,0	22,5	18,0
Air handling section fans (supply)							
Air flow	3	[l/s]	149	197	244	324	492
Air flow	3	[m ³ /h]	535	710	880	1165	1770
Noise levels							
Sound pressure level (1 m)	4	[dB(A)]	34	41	47	34	43
Sound power level	4	[dB(A)]	47	54	60	48	57

(1) Water temperature in / out 7°C / 12°C
Indoor air at 27°C D.B. / 19,5°C W.B.

Air flow at maximum speed (with air filter)

(2) Water inlet 70°C and outlet 60°C

Indoor air temperature at 20°C D.B.

Air flow at maximum speed (with air filter)

(3) Nominal airflow at maximum speed (with air filter)

(4) Sound levels refer to units with full load under nominal test conditions. The sound pressure is measured at 1 m from the external surface of the unit in open field conditions.

Electrical data - 4-pipe (CC4)

High efficiency EC fan

Voltage variation 230/1/50 ± 10%

Size			007.0	011.0	015.0	021.0	031.0
F.L.A. - Full load current at max admissible conditions							
FLA Total		[A]	0,24	0,34	0,64	0,34	0,99
F.L.I. - Full load power input at max admissible conditions							
FLI Total		[kW]	0,016	0,031	0,062	0,033	0,108

(1) Water temperature in / out 7°C / 12°C

Indoor air at 27°C D.B. / 19,5°C W.B.

Air flow at maximum speed (with air filter)

(2) Water inlet 70°C and outlet 60°C

Indoor air temperature at 20°C D.B.

Air flow at maximum speed (with air filter)

RE - Electric heaters

The “cassette” 2-pipe models are available with electric resistance that is controlled in place of the heating battery valve.

The electric resistance is controller in place of the hot water valve and not as integration to it.

The resistance is hermetically sealed and supplied inside the battery pipes and therefore can be only factory mounted.

A specific electronic board is fitted in the unit control panel and it is connected to the resistance and to the safety thermostat.

When the safety thermostat operates, it keeps open the resistance supply relays on the electronic board.

The rearmement is by electric means, cutting off the supply to the unit.

Main technical specifications of the electric heaters

Size	007.0	011.0	015.0	021.0	031.0	041.0
Nominal installed power	1500 Watt	2500 Watt	2500 Watt	3000 Watt	3000 Watt	3000 Watt
Nominal power voltage	230V ~	230V ~	230V ~	400V ~	400V ~	400V ~
Number and section of connecting wires	3 x 1,5mm ²	3 x 2,5mm ²	3 x 2,5mm ²	5 x 1,5mm ²	5 x 1,5mm ²	5 x 1,5mm ²
Current input (Max)	7 A	11 A	11 A	5 A	5 A	5 A
Recommended fuse (Type gG) for overload protection	8 A	12 A	12 A	6 A	6 A	6 A

Max ambient temperature for ELFOspace BOX2 with electric coil in heating mode = 25°C.

Configuration not available for sizes 005.0.

Wiring diagrams 230/1/50 electric heaters

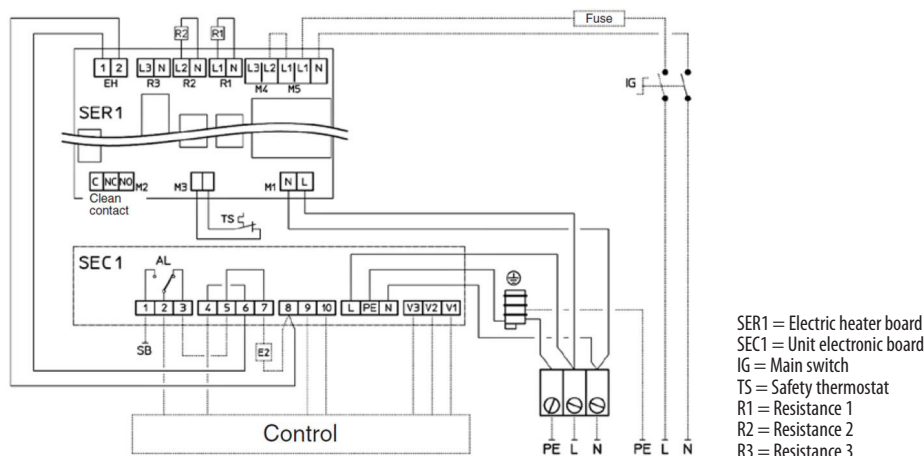

Wiring diagrams 400/3/50 electric heaters

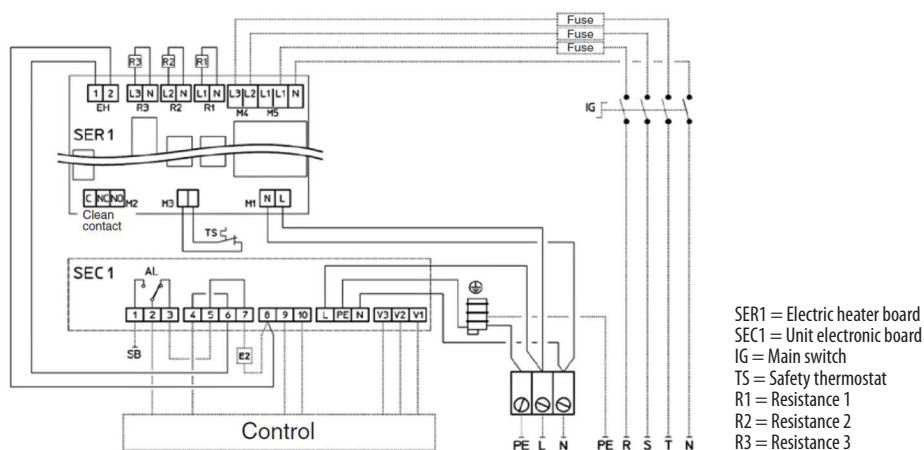

The power supply to the electric heaters must be separate from the power supply to the unit, and have its own earth.

Accessories separately supplied

PLAX - Plastic frame for air supply and return (obligatory accessory)

Intake grid, frame and louvres made of ABS in RAL 9003 (white colour):

- Sizes from 005.0 to 015.0 = 600 x 600mm
- Sizes from 021.0 to 041.0 = 800 x 800mm



Obligatory accessory.



MAUXX - Primary air kit

This is used to introduce primary air into the environment directly through the diffuser. The kit includes a flow separator to be fitted inside the cassette, and a circular fitting (CAUX) for connection to the flexible system ducting. The flow of air is sent directly to just one of the outlet louvres, without passing through the coil. The air flow of fresh air introduced into the environment depend on the inlet sytatic pressure.

Correlation between flow-rate / static pressure

005.0 - 007.0 - 011.0 - 015.0		021.0 - 031.0 - 041.0	
Ø 150mm		Ø 180mm	
Q m³/h	Pa	Q m³/h	Pa
80	3	160	3
120	8	200	8
160	15	300	15
200	25	400	25
240	36	500	36

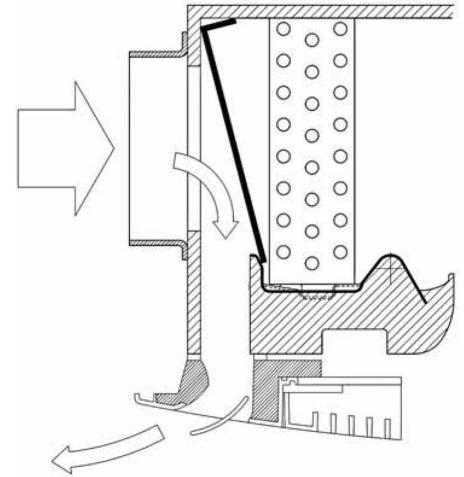

CAUX - Auxiliary air distribution duct

Two air outlets are provided on the side of the unit for connection to separate supply air outlets. They can be used to supply air from the fan coil unit to distant areas of a room or even to a different room. The total air flow does not change. The air flow at high speed depending on the air duct pressure drop is shown in the tables below.

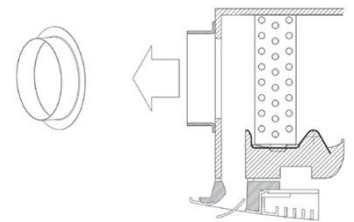

One outlet used

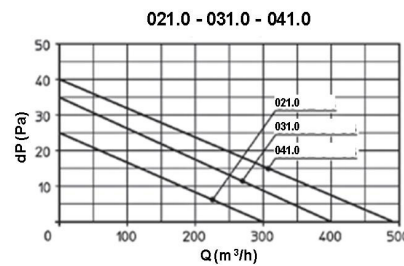
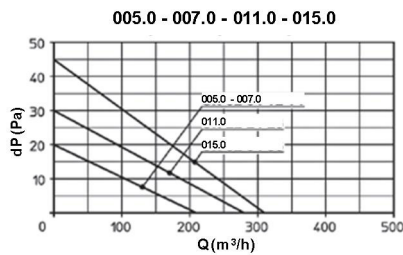

Legend:
Dp = Pressure drop (Pa)
Q = Air flow [m³/h]

Two outlets used

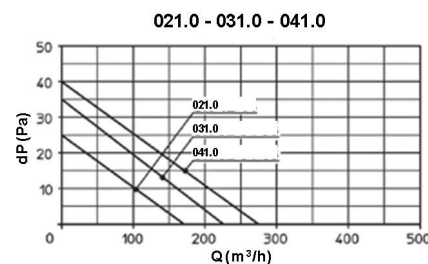
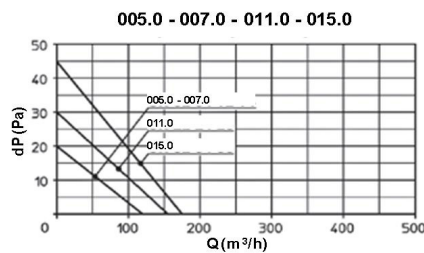

Legend:
Dp = Pressure drop (Pa)
Q = Air flow [m³/h]



Note: all air ducts must be insulated in order to avoid condensation.

CONRX - Fresh air connection

Adapter for circular ducts Ø105mm.

2V2X - ON/OFF 2 way valve kit for 2-pipe system

2V4X - ON/OFF 2 way valve kit for 4-pipe system

3V2X - Three-way valve kit for 2-pipe system type "on/off"

3V4X - Three-way valve kit for 4-pipe system type "on/off"

Valve set, 2 or 3 ways, ON-OFF, with thermoelectric actuator.

The set includes connection pipes.

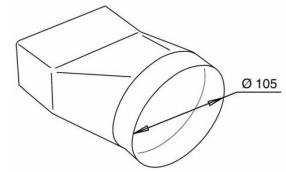

The maximum pressure drop across the fully open valve should not exceed 25 kPa for cooling operation and 15 kPa for heating operation.



Pressure drop

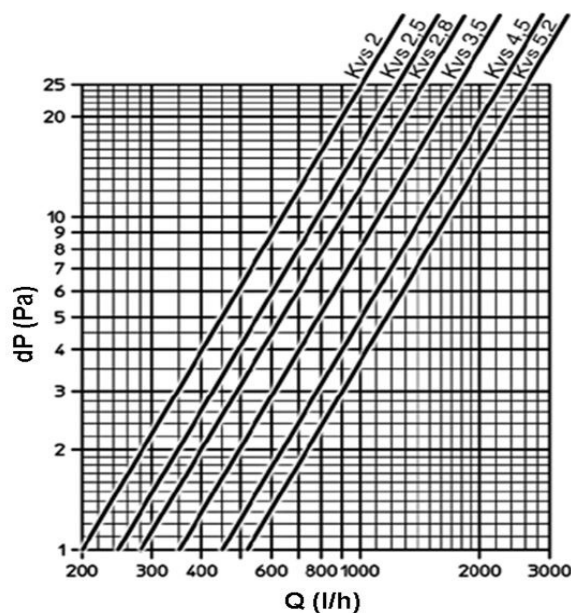

Legend:
Dp = Pressure drop (Pa)
Q = Water flow rate (l/h)

Technical data

Rated pressure	16 bar
Max indoor temperature	50°C
Max water flow temperature	110°C
Power supply	230 V - 50/60 Hz
Rating	3 VA
Protection	IP 43
Travel time	ca. 3 min.
Rated pressure	50%

Valves characteristics

ELFO SPACE BOX 2 CC2		005.0		007.0		011.0		015.0		021.0		031.0		041.0	
		2V2X	3V2X	2V2X	3V2X	2V2X	3V2X	2V2X	3V2X	2V2X	3V2X	2V2X	3V2X	2V2X	3V2X
A*	Ø	3/4"	3/4"	3/4"	3/4"	3/4"	3/4"	3/4"	3/4"	1"	1"	1"	1"	1"	1"
Kvs	m³/h	2.8	2.5	2.8	2.5	2.8	2.5	2.8	2.5	5.2	4.5	5.2	4.5	5.2	4.5
Dp max**	kPa	50	50	50	50	50	50	50	50	60	50	60	50	60	50

ELFO SPACE BOX 2 CC4		005.0		007.0		011.0		015.0		021.0		031.0		041.0	
		2V4X	3V4X	2V4X	3V4X	2V4X	3V4X	2V4X	3V4X	2V4X	3V4X	2V4X	3V4X	2V4X	3V4X
A*	Ø	3/4"	3/4"	3/4"	3/4"	3/4"	3/4"	3/4"	3/4"	1"	1"	1"	1"	1"	1"
Kvs	m³/h	2.8	2.5	2.8	2.5	2.8	2.5	2.8	2.5	5.2	4.5	5.2	4.5	5.2	4.5
Dp max**	kPa	50	50	50	50	50	50	50	50	60	50	60	50	60	50
B*	Ø	3/4"	3/4"	3/4"	3/4"	3/4"	3/4"	3/4"	3/4"	3/4"	3/4"	3/4"	3/4"	3/4"	3/4"
Kvs	m³/h	2.8	2.5	2.8	2.5	2.8	2.5	2.8	2.5	2.8	2.5	2.8	2.5	2.8	2.5
Dp max**	kPa	50	50	50	50	50	50	50	50	50	50	50	50	50	50

CC2 = 2-pipe system
CC4 = 4-pipe system
A = Main coil (Cooling)
B = Auxiliary coil (Heating)

* = External thread
** = Max difference of pressure at closed valve

CIVX - Fairing for in-view installation

The body for visible installation has been designed for all rooms in which false ceilings have not or can not be provided in which to insert the mechanical and electrical systems.

The covering cabinet matches perfectly with the air intake and delivery grille, conserving the design and charm that characterize the ELFOSpace BOX2 series.

Plumbing connections can be faced upwards.

The series with a body for visible installation includes 7 models, with an installation height of up to 5 m, thanks to the great versatility of adjustment of the air diffusion fins.

All of the technical characteristics described in the previous pages remain valid, keeping in mind that:

- the series with body for visible installation has a single thermal exchange coil (2-pipe system)
- no primary air
- no additional electrical battery

The version with body for visible installation includes a special covering packaged separately which must be applied only after the ELFOSpace BOX2 has been installed with electrical and plumbing connections complete.



Dimensional drawings

Sizes 005.0 - 07.0 - 011.0 - 015.0

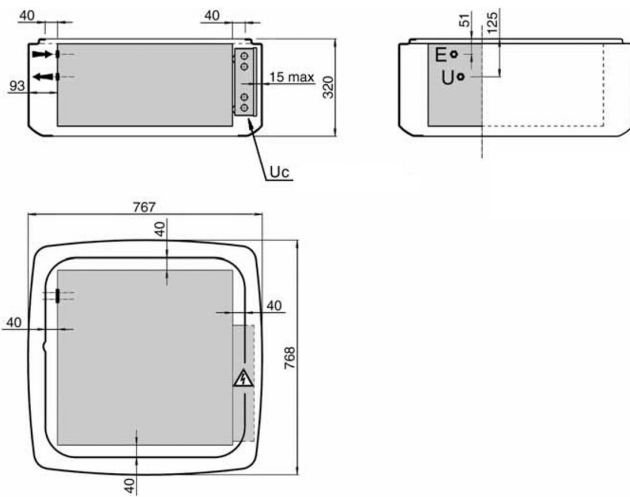

Uc = Cable exit
E = Exchanger water inlet
U = Exchanger water outlet

Sizes 021.0 - 031.0 - 041.0

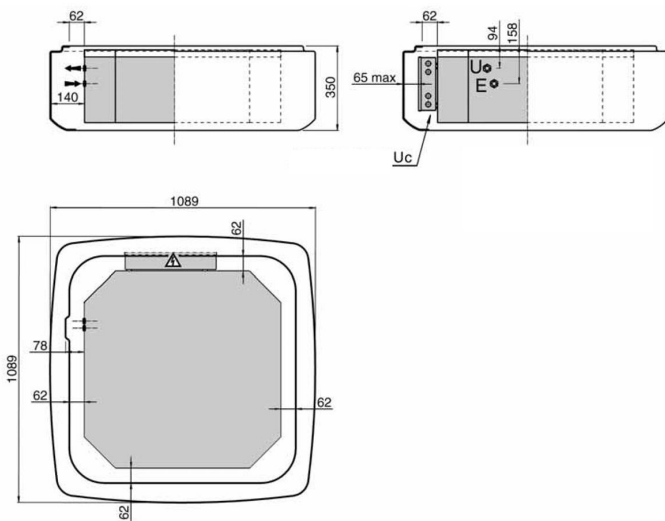

Uc = Cable exit
E = Exchanger water inlet
U = Exchanger water outlet



Warning: the electrical and water connections must enter the unit from above and must not interfere with the casing.

TIMBX - Infra-red remote control with receiver for MB electronics

The infra-red remote control with receiver, supplied separately, allows setting by a remote position the fan coil operation parameters.

The infra-red remote control features the following functions:

- switch the appliance on and off
- temperature set
- set the fan speed (MIN - MED - MAX or AUTO)
- set the operation mode (fan only, cooling, heating; auto for 4-pipe systems with mode selection depending on the air temperature)
- time setting
- 24 hours ON/OFF program



HIDE2X - Remote control with E/I +3V + on/off for wall installation

HID-E2 electro-mechanical room thermostat for wall installation.

It allows:

- setting the desired temperature (10-30°C)
- selection of the 3 speeds (MIN - MED - MAX)
- ON/OFF
- manual Summer / Winter change
- continuous or thermostat-based ventilation
- control of on/off water valve

It can be connected to the remote air probe (PTABX)

Dimensions: 184x82x27 mm

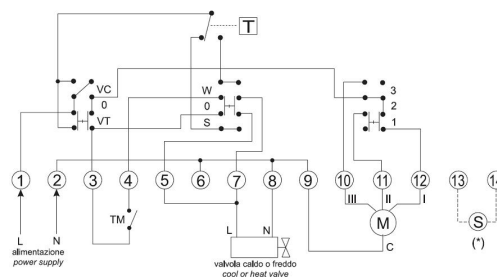

HIDE3X - Plurifunctional remote control for wall installation

HID-E3 electro-mechanical room thermostat for wall installation.

It allows:

- automatic fan speed adjustment (MIN - MED - MAX)
- silent operation (minimum fan speed)
- ON/OFF
- ambient temperature adjustment via the control knob: the knob's central position corresponds to the comfort condition (20°C in heating mode, 24°C in cooling mode). The temperature can be changed by +/- 5°C in relation to the comfort condition by turning the knob
- automatic selection of the Summer/Winter season: the heating or cooling mode is selected automatically by detecting the water temperature supplied to the fan-coil (water temperature below 17°C = operation in cooling mode, water temperature above 21°C = operation in heating mode)
- Hot Start function: in heating mode the fan does not start until the thermal coil is not hot enough
- destratification cycle
- dirty filter warning
- minimum water temperature probe

Dimensions: 184x82x27 mm

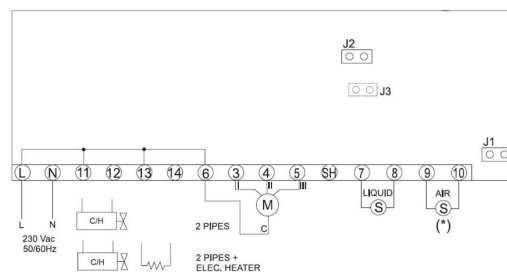

HIDT2X - HID-T2 electronic room control

The HID-T2 room thermostat makes it possible to interface with the control module of units equipped with CLIVET TALK TERMINAL SPACE electronics (CTSP1) and to manage one or more thermostat units.

The room thermostat allows the following functions:

- setting of the desired temperature
- selection of the 3 speeds (MIN - MED - MAX) either manually or automatically
- ON/OFF
- change summer/winter automatically or manually with digital input
- select operation in economy mode
- set the unit's operating parameters
- setting of ventilation-only mode
- management of diagnostics with specific code for type of error

Dimensions: 123x86x27 mm

The thermostat is connected to the unit via a shielded twisted pair at a maximum distance of 15 m.



HIDT3X - HID-T3 electronic room control

The HID-T3 room thermostat makes it possible to interface with the control module of units equipped with CLIVET TALK TERMINAL SPACE electronics (CTSP1) and to manage one or more thermostat units.

The room thermostat allows the following functions:

- setting of the desired temperature
- selection of the 3 speeds (MIN - MED - MAX) either manually or automatically
- ON/OFF
- change summer/winter automatically or manually with digital input
- select operation in economy mode
- set the unit's operating parameters
- setting of ventilation-only mode
- humidity probe management
- humidity display
- management of diagnostics with specific code for type of error

Dimensions: 123x86x27 mm

The thermostat is connected to the unit via a shielded twisted pair at a maximum distance of 15 m.



HIDT12X - HID-T12 flush-mounted electronic room control

The HID-T12 room climate control makes it possible to interface with the control module of units equipped with CLIVET TALK TERMINAL SPACE electronics (CTSP1) and to manage one or more thermostat units.

The room thermostat allows the following functions:

- setting of the desired temperature
- selection of the 3 speeds (MIN - MED - MAX) either manually or automatically
- ON/OFF
- change summer/winter automatically or manually with digital input
- select operation in economy mode
- set the unit's operating parameters
- setting of ventilation-only mode
- management of diagnostics with specific code for type of error

The thermostat is connected to the unit via a shielded twisted pair at a maximum distance of 15 m.

The supplied fixing hangs allow mounting the thermostat to the plastic boxes (not supplied) normally used in the houses.



PTABX - Remote probe for room air temperature for electromechanical thermostats

Sensors and thermostats should be located in the reference rooms, in a position enabling the actual measurement of the temperature, without any external factors influence.

Best technical solution to measure the correctly room temperature is to install the sensor in the room, on the wall of the same.

The remote room air sensor can be connected to the HID-E_ room thermostats complete with sensor input.

DCPX - Control device for more units with a single room control

Control device from single thermostat for max. 4 units compatible with HID-E electro-mechanical thermostats.

Dimensional drawings

600x600

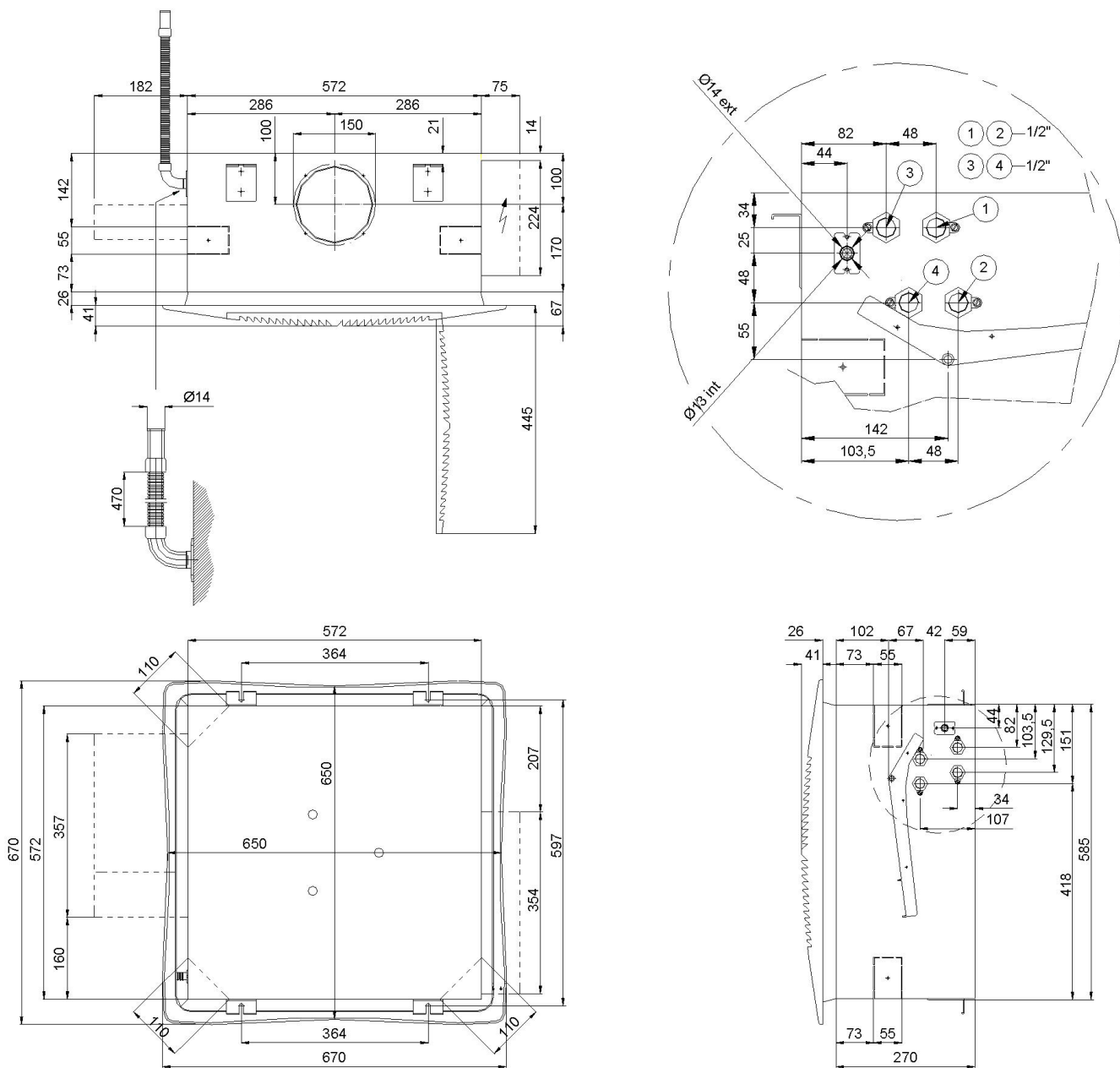

1. Additional coil water inlet 1/2" (4-pipe system)
2. Additional coil water outlet 1/2" (4-pipe system)
3. Water outlet 1/2" (standard unit)
4. Water inlet 1/2" (standard unit)

General dimensions and weights

Size		CC2				CC4			
		005.0	007.0	011.0	015.0	005.0	007.0	011.0	015.0
Length	mm	572	572	572	572	572	572	572	572
Depth	mm	572	572	572	572	572	572	572	572
Height	mm	270	270	270	270	270	270	270	270
Operating weight	kg	25	25	27	27	27	27	27	27
Shipping weight	kg	34	34	36	36	36	36	36	36



The weights indicated are composed by the weight of the unit and the intake grid (PLAX) obligatorily supplied.

Dimensional drawings

800x800

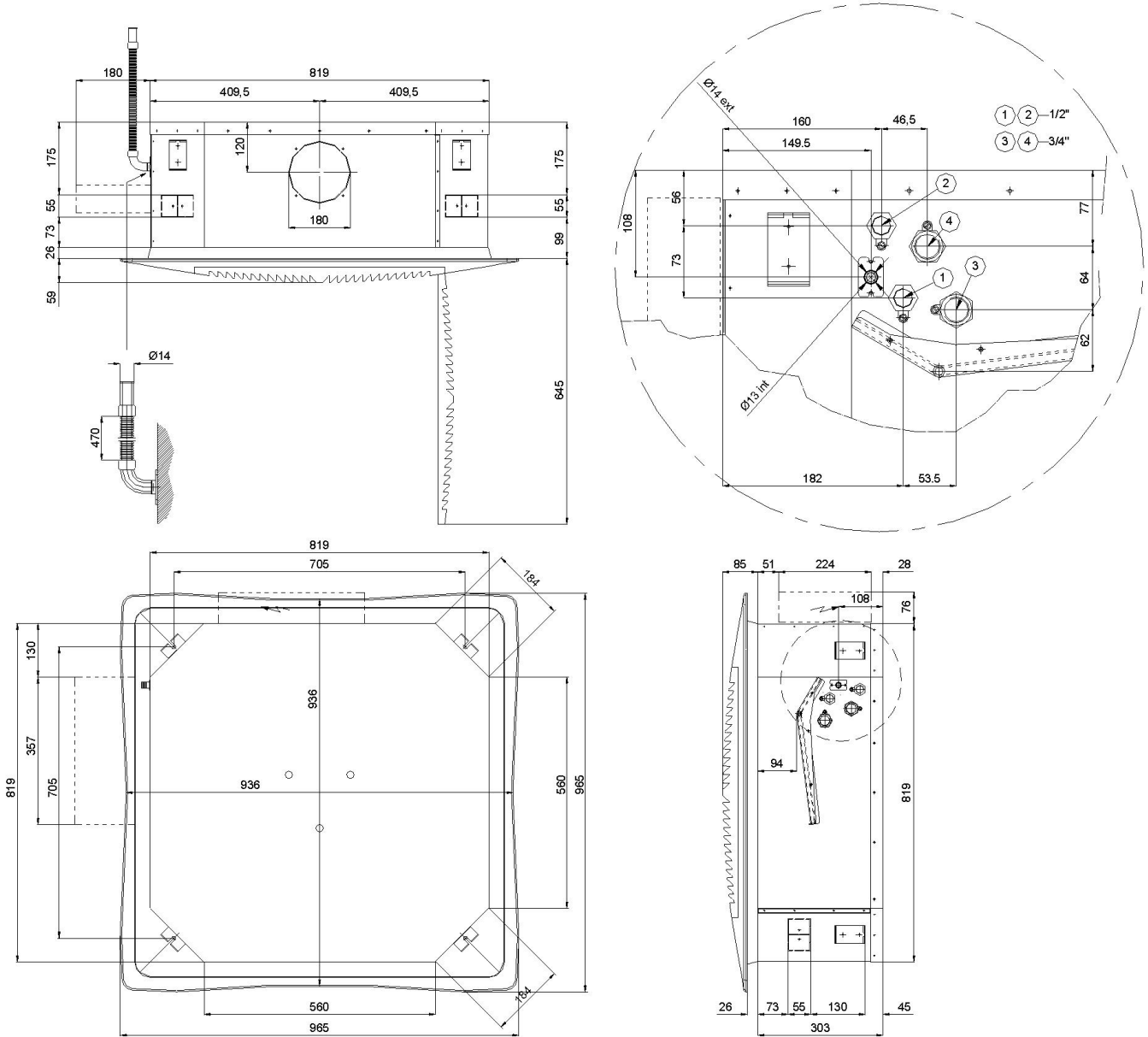

1. Additional coil water inlet 1/2" (4-pipe system)
2. Additional coil water outlet 1/2" (4-pipe system)
3. Water inlet 3/4" (standard unit)
4. Water outlet 3/4" (standard unit)

General dimensions and weights

Size		CC2			CC4		
		021.0	031.0	041.0	021.0	031.0	041.0
Length	mm	819	819	819	819	819	819
Depth	mm	819	819	819	819	819	819
Height	mm	303	303	303	303	303	303
Operating weight	kg	42	45	45	45	45	45
Shipping weight	kg	54	57	57	57	57	57

The weights indicated are composed by the weight of the unit and the intake grid (PLAX) obligatorily supplied..

Packing volume

Standard unit

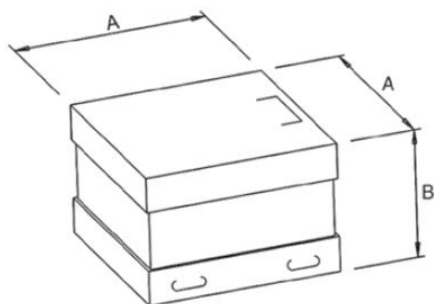

Plastic frame for air supply and return (PLAX)

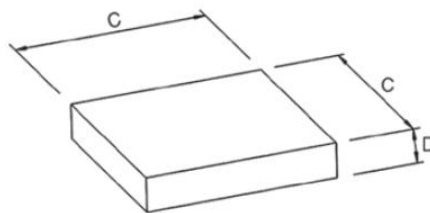

Size		005.0	007.0	011.0	015.0	021.0	031.0	041.0
A	mm	790	790	790	790	1050	1050	1050
B	mm	350	350	350	350	400	400	400
C	mm	750	750	750	750	1000	1000	1000
D	mm	150	150	150	150	200	200	200

Functional spaces

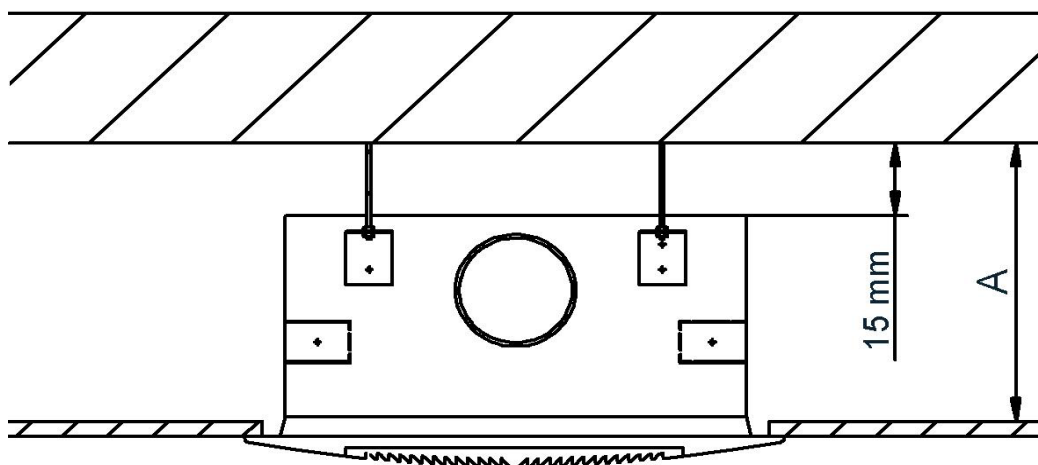

Size		005.0	007.0	011.0	015.0	021.0	031.0	041.0
A	mm	310	310	310	310	345	345	345



CLIVET SPA

Via Camp Lonc 25, Z.I. Villapaiera - 32032 Feltre (BL) - Italy
Tel. + 39 0439 3131 - Fax + 39 0439 313300 - info@clivet.it

CLIVET UK LTD (Sales)

4 Kingdom Close, Segensworth East - Fareham, Hampshire - PO15 5TJ - United Kingdom
Tel. + 44 (0) 1489 572238 - Fax + 44 (0) 1489 573033 - info@clivet-uk.co.uk

CLIVET AIRCON LTD (Service and Maintenance Division)

Units F5&F6 Railway Triangle Ind Est, Walton Road - Portsmouth, Hampshire - PO6 1TG - United Kingdom
Tel. +44 (0) 2392 381235 - Fax. +44 (0) 2392 381243 - info@clivetaircon.co.uk

CLIVET ESPAÑA COMERCIAL S.L. (Sales)

Calle Gurb, 17 1º 1ª - 08500 Vic, Barcelona - España
Tel: +34 93 8606248 - Fax +34 93 8855392 - info@clivetcomercial.com

CLIVET ESPAÑA S.A.U. (Service and Maintenance Division)

Calle Real de Burgos Nº 12 - 28860 Paracuellos del Jarama, Madrid - España
Tel. +34 91 6658280 - Fax +34 91 6657806 - info@clivet.es

CLIVET GmbH

Hummelsbütteler Steindamm 84, 22851 Norderstedt - Germany
Tel. + 49 (0) 40 32 59 57-0 - Fax + 49 (0) 40 32 59 57-194 - info.de@clivet.com

CLIVET NEDERLAND B.V.

Siliciumweg 20a, 3812 SX Amersfoort - Netherlands
Tel. + 31 (0) 33 7503420 - Fax + 31 (0) 33 7503424 - info@clivet.nl

CLIVET RUSSIA

Elektrozavodskaya st. 24, office 509 - 107023, Moscow, Russia
Tel. + 74956462009 - Fax + 74956462009 - info.ru@clivet.com

CLIVET MIDEAST FZCO

Dubai Silicon Oasis (DSO), High Bay Complex, Ind Unit No. 3, PO BOX 28178, Dubai, UAE
Tel. + 9714 3208499 - Fax + 9714 3208216 - info@clivet.ae

CLIVET AIRCONDITIONING SYSTEMS PRIVATE LIMITED

4BA, Gundecha Onclave - Kherani Road, Saki Naka, Andheri (East) - Mumbai 400 072 - India
Tel. +91 22 6193 7000 - Fax +91 22 6193 7001 - info.in@clivet.com